

BUILDING
COMMON GROUND



Stremaform[®]

Formwork elements





BUILDING
COMMON GROUND



Stremaform®

Formwork elements

Content

Applications	4
Stremaform® system	6
Material types	7
Stremaform® for working joints	8
Preparation categories	10
Stremaform® spacer – the combined spacer	12
Stremaform® flat material	13
Stremaform® strong	14
Stremaform® with indented joint	15
Stremaform® with metal water stop	16
Stremaform® with coated metal water stop	16
Stremaform® with pvc/rubber water bar cage	17
Stremaform® fixing anchor	18
Stremaform® formwork for underwater elements	19
Stremaform® kicker formwork	20
Stremaform® “A-Bock” – free standing	21
Stremaform® foundation box-outs	22
Stremaform® box-outs	23
Stremaform® hopper formwork	24
Stremaform® for controlled crack joints	25
Stremaform® for expansion joints – overview	27
Stremaform® for expansion joints – preparation categories ..	28
Order form - Stremaform® working joints	32
How tos	38

Working joint

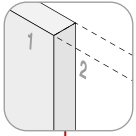

Box-out

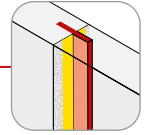
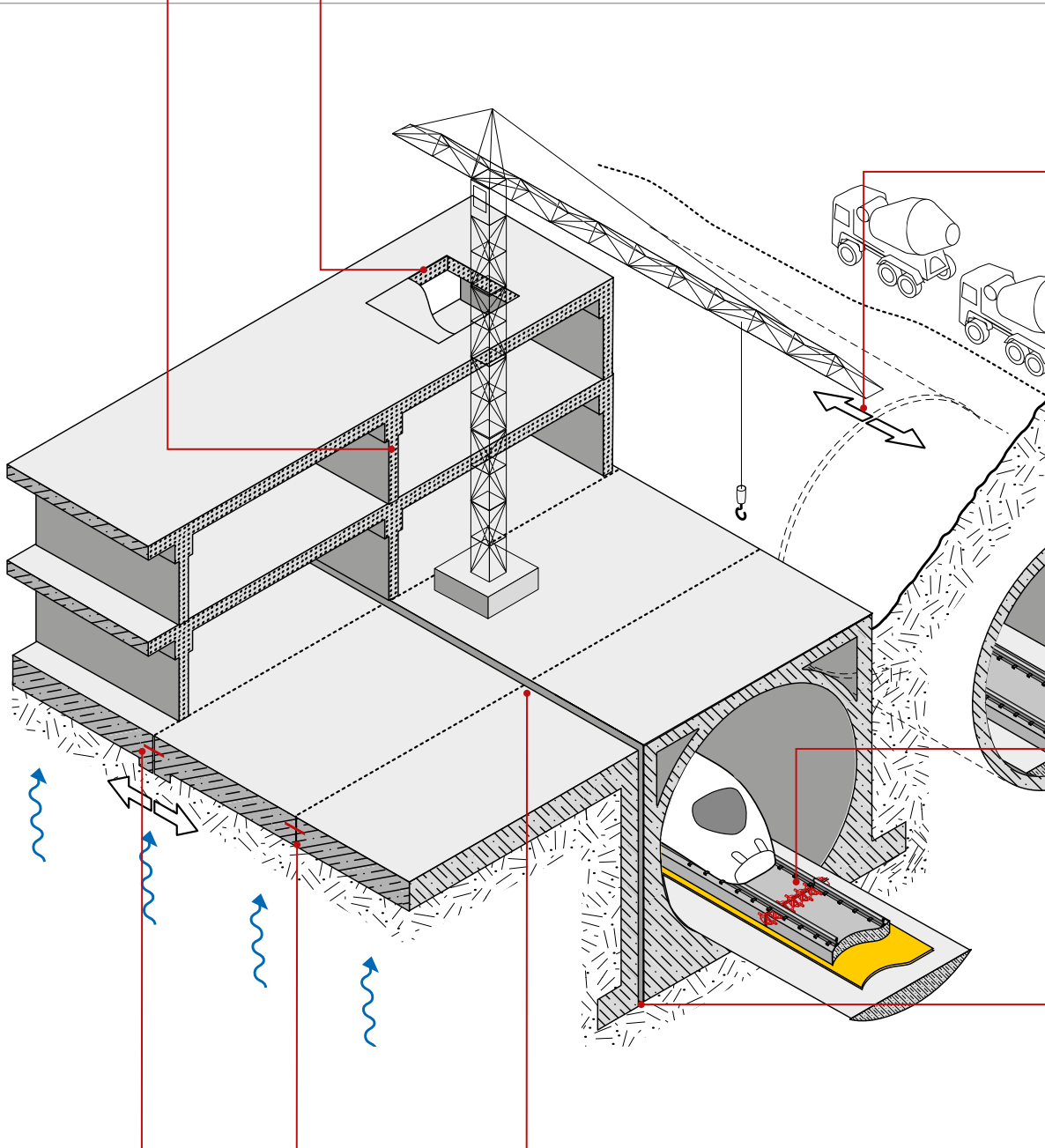
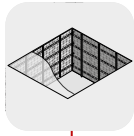

Controlled crack joint with water stop

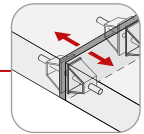

Expansion joint with transmission of dynamic loads

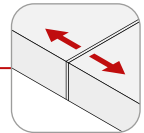

Expansion joint

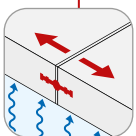

Expansion joint with water stop

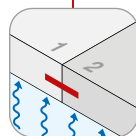

Working joint with water stop

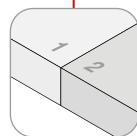

Working joint

Working joints

Stremaform® formwork elements for working joints divide large structural components into concrete pours. Their positioning is planned in accordance with work flow requirements or as part of the structural design. Working joints can be sealed with water stops – such as rubber water bars or metal water stops. Transverse force dowels (Egcodubel) are used to transfer loads.

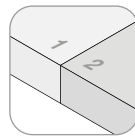

Working joint

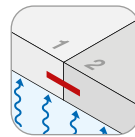

Working joint with water stop

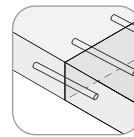

Working joints with force transmission

Stremaform® is suited for all types of working joints.

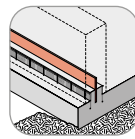

Kicker formwork

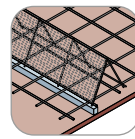

Stremaform® "A-Bock" - free standing

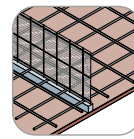

Stremaform® spacer

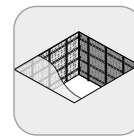

Box-out

Controlled crack joint

Stremaform® controlled crack joints are used to produce intended cracks in working joints by deliberate weakening of the concrete cross section. The cross section is weakened by introducing a separation layer, which prevents the production of a concrete bond within one third of the concrete cross section.



Controlled crack joint

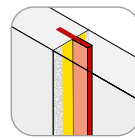

Controlled crack joint with water stop

Expansion joints

Expansion joints or movement joints separate structural elements made of concrete from each other. EPS or mineral wool inserts are used to form the required joint between the structural elements. Watertight expansion joints are produced by incorporating a water stop.

Stremaform® elements are prefabricated in our factory, ready for installation on site. Stremaform® elements can be manufactured with or without a rubber water bar cage. The rubber water bar is installed in the cage at the construction site.

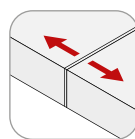

Expansion joint

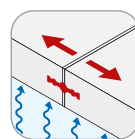

Formwork element with pvc/rubber water bar

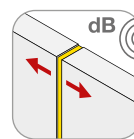

Sound joint (wall)

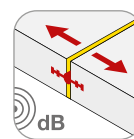

Sound joint with water bar (base slab)

Expansion joints with force transmission

Stremaform® formwork elements for expansion joints can be fitted in our factory with dowels (Egcodubel) or with transverse force dowels (Egcodorn) for absorption of shear forces. For mass-spring-systems we use dowels which have also been approved for transmission of dynamic loads.

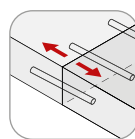

Expansion joint with transverse force dowels (Egcodubel) for static loads

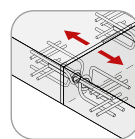

Expansion joint with transverse force dowels (Egcodorn) for static loads

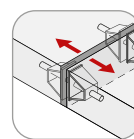

Expansion joint with transverse force dowel (Egcodorn) for dynamic loads

Stremaform® formwork elements are used as lost formwork in floor slabs, ceilings and walls. The expanded metal that is welded between the bars of a specially designed reinforcing steel mesh gives rise to a rough surface. The reinforcement can be continued without a break into the second concrete pour.



Stremaform®

Stremaform® flat is used for medium-sized structural components, installed between the upper and lower reinforcement layers.

Stremaform® in the concrete gives a rough surface that satisfies the requirements of an indented joint according to DIN 1045-1 and/or Eurocode 2 and does not need scabbling.

A metal water stop or a pvc/rubber waterbar support cage can be integrated in our factory if required.

Delivery is made precisely in accordance with your layout specifications.

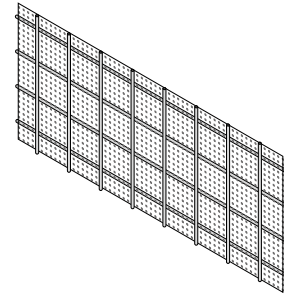

Stremaform® for self compacting concrete (SCC)

Stremaform® SCC flat material features a fine-mesh expanded metal with flow-resistant characteristics for use with self-compacting concrete. It can be combined with a factory-fitted integrated metal water stop, integrated waterbar cage or factory-fitted stiffening. It is installed between the upper and lower reinforcement layers. Delivery is made precisely in accordance with your layout specifications.

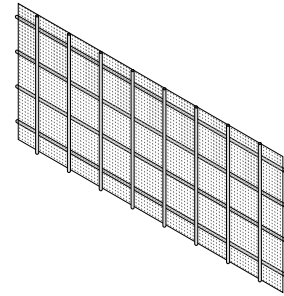

Stremaform® strong

Stremaform® strong with factory-fitted stiffening made of lattice beams is intended for larger structural components. Here, too, a water stop or waterbar cage can be integrated at the factory if required. Delivery is made precisely in accordance with your layout specifications.

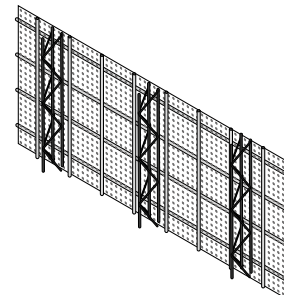

Stremaboard

Stremaboard consists of a profiled, lightweight expanded metal:

The profile satisfies requirements to DIN EN 1992-1-1, so that working joints produced with Stremaboard are classified as indented joints.

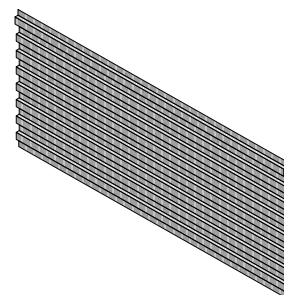

The following documents are kept available on our website for you to download:

Stremaform® elements in working joints version to DIN EN 1992-1-1

Experts report issued by Prof. Dr.-Ing.
Harald Sipple

Users' declaration for the "Stremaform® system – formwork elements for working joints" in walls, base slabs, permanent edging formwork DB Netz AG, Frankfurt"

DB Netz AG, Frankfurt

European Technical Assessment Fradiflex® – ETA-15/0914

DIBt,
Deutsches Institut für Bautechnik

Stremaform® for limited structural element height

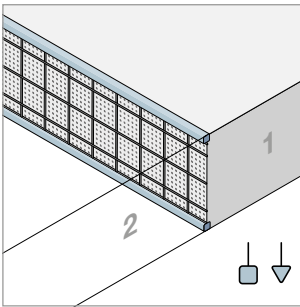

Stremaform® formwork element with integrated spacers

Stremaform® types

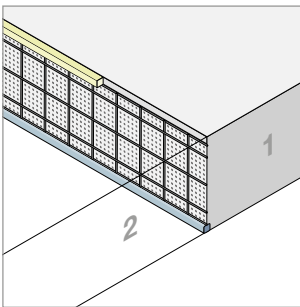

Stremaform® flat material

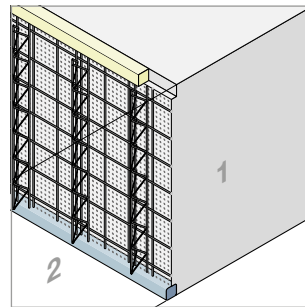

Stremaform® strong

Stremaform® for working joints with water stop

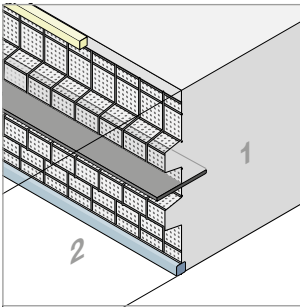

Formwork element with metal water stop

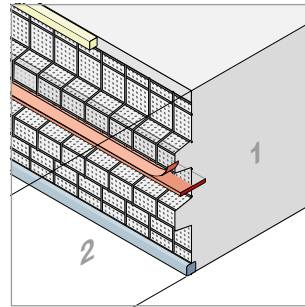

Formwork element with coated metal water stop

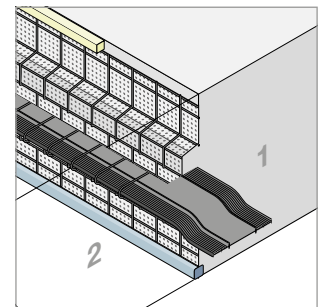

Formwork element with pvc/rubber water bar cage

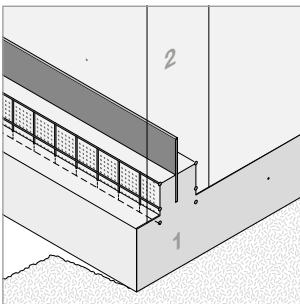

Kickers base slab/wall with metal water stop

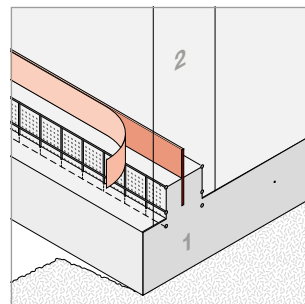

Kickers base slab/wall with coated metal water stop

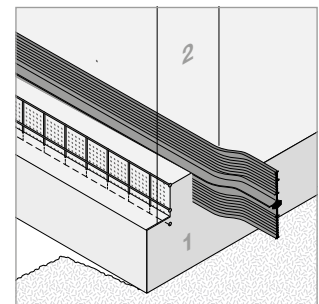

Kickers base slab/wall with pvc/rubber water bar

Other designs and types of assembly

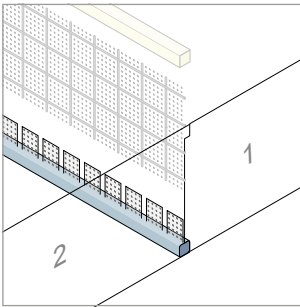

Stremaform® spacer with fibre concrete rail

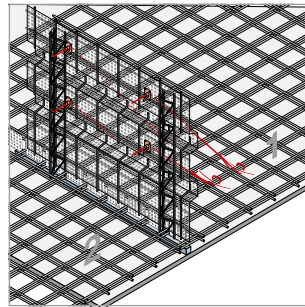

Stremaform® fixing anchor

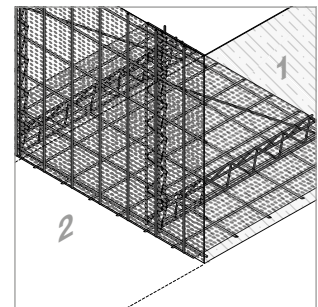

Formwork element for underwater base slabs

Different types of working joints

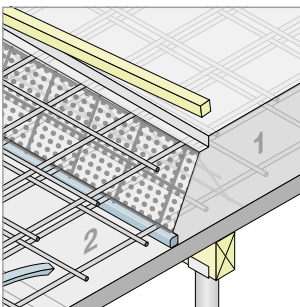

Stremaform® "A-Bock" - free standing formwork element

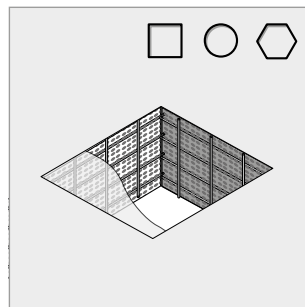

Box-out

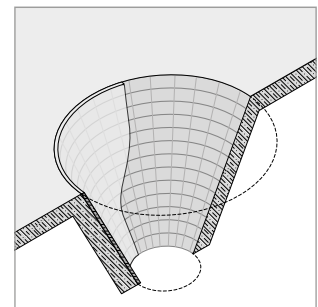

Hopper formwork elements

Stremaform® for controlled crack joints

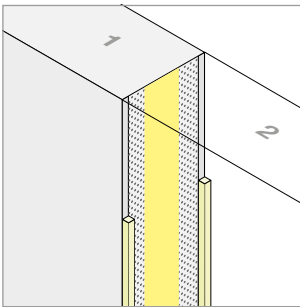

Formwork element for controlled crack joints

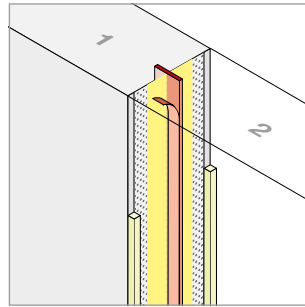

Formwork element for controlled crack joints with coated metal water stop

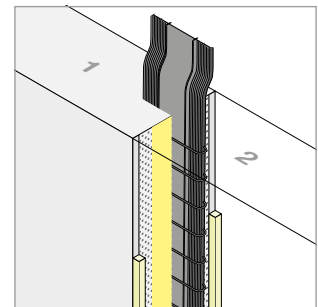

Formwork element for controlled crack joints with pvc/rubber water bar cage

Preparation categories (design categories)

Stremaform® working joints for slabs and walls are supplied in uniform sections. To simplify planning, manufacture and delivery there are standardised units for various purposes. Depending on your specific requirements, Stremaform® units are individually assembled within the design categories “Standard”, “Standard-to-length”, and “Tailored fit”.

All design categories are available in individual heights (installation dimensions) for the corresponding component thickness.

Standard system

This category is made up exclusively of standard-length elements ($l = 2.40$ m and 1.20 m) and standard formwork elements (for changes in the joint layout) which are produced and supplied for the working joint. Any necessary adaptations of the standard elements are carried out by the customer on the building site (element length, conical progression, projections, penetrations, etc.).

Advantages

- Condensed range – reduced complexity!
- Optimal system – where time is of the essence on site!
- Simplified logistics

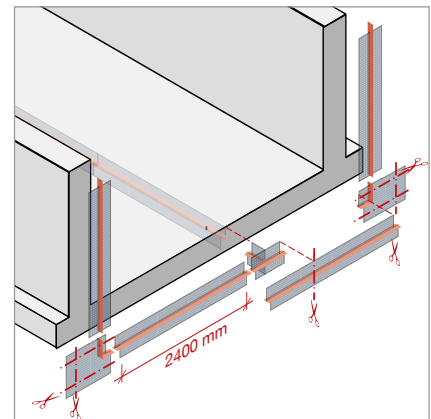

Standard system, to length

This version encompasses standard units in variable lengths (except for corner applications). The overall joint length corresponds with the plans and no longer needs to be cut to length on site. On-site adjustment of units will only occur in the case of tapered joint layouts, component projections or penetrations.

Advantages

- Simple on-site adjustments, if required
- Optimum system if detailed planning is not yet complete
- Simplified logistics

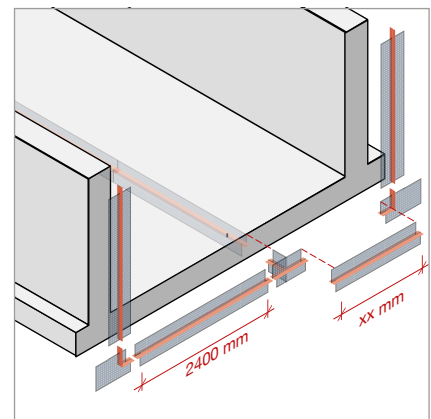

Tailored fit

For complex system sections, it pays to have perfectly-fitted working joints. Our application technology department can optimise and design any cross-sectional shape and joint layout. No adjustments are needed on site, even for complex forms. The final delivery consists of a mix of standard and custom formwork elements, which fit exactly in accordance with the customer's drawing.

Advantages

- Ready-to-install system
- No cutting on-site to length
- Formwork units and additional accessories can be provided according to your individual requirements
- System reconciliation between building site and planner

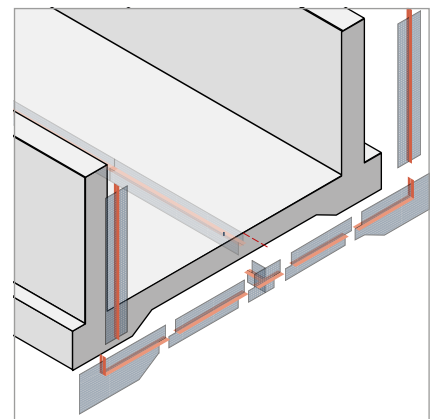

Units

With standardised Stremaform® and formwork units, as specified below, it is possible to individually produce any working joint geometry.

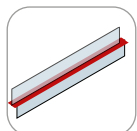
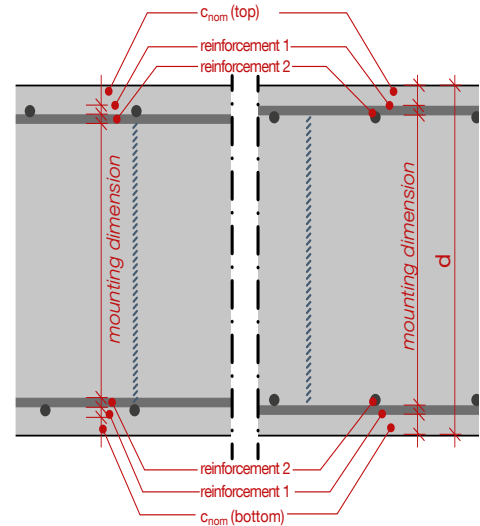

Standard
2400 mm

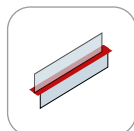

Standard
1200 mm

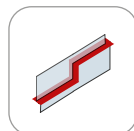

Standard
Height offset



Standard
Wall transition unit



Corner element

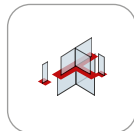

T-element

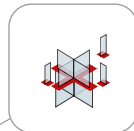

Crossing

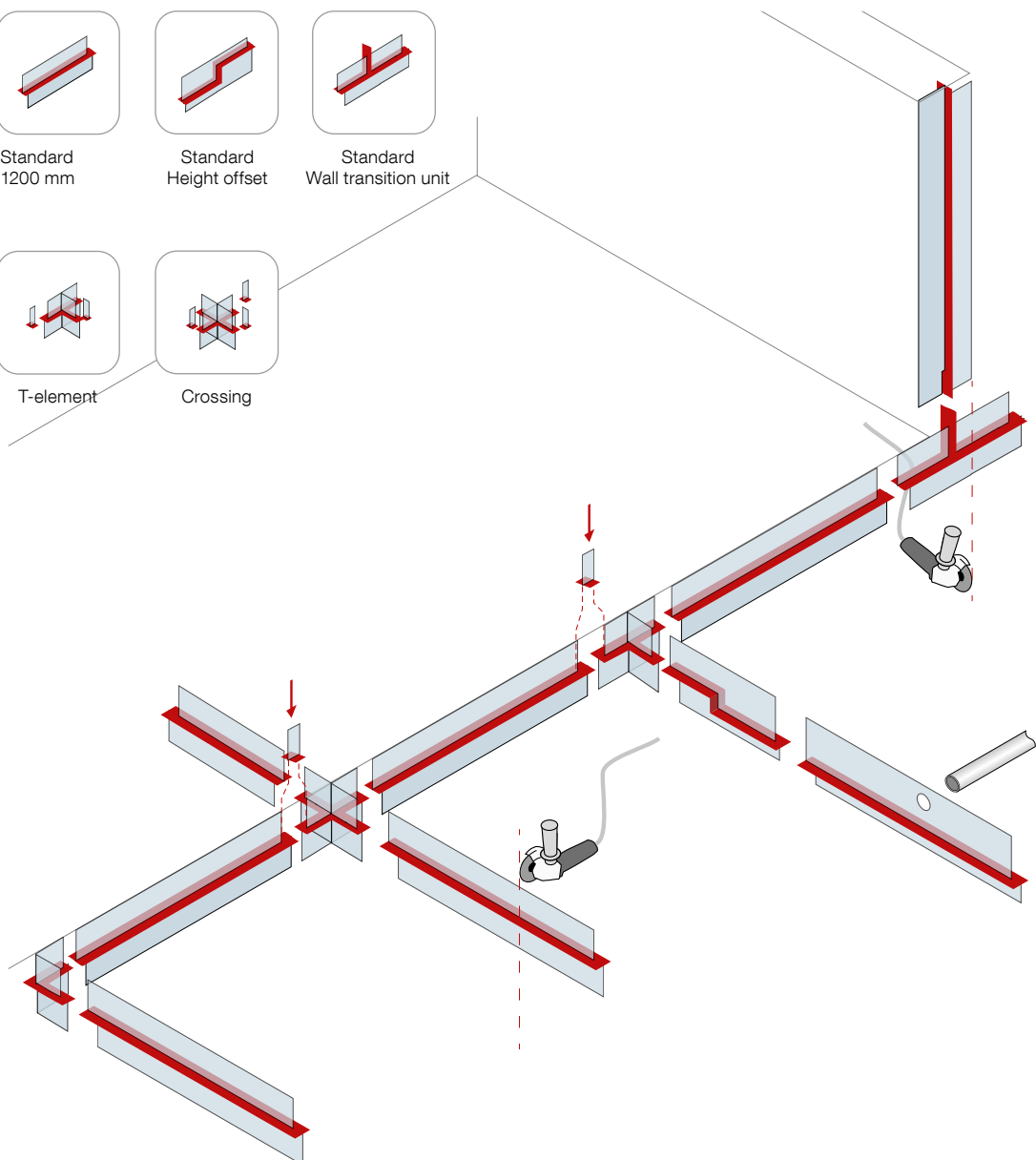

Stremaform® spacer – the combined spacer

Stremaform® spacers are used to maintain the concrete cover and to seal the gap beneath the bottom layer of continuous reinforcement.

The spacers thus prevent leakage of cement paste and avoid the need for laborious cleaning and reworking. During production at our factory, the correct spacer for the cover is used and the spacing and widths of the Stremaform® combs are chosen to suit the reinforcement layout. The height of Stremaform® combs can also be altered to suit multiple layers of reinforcement.

- Fibre reinforced concrete rails are available in square or triangular
- A large range of concrete covers are available
- Suitable for slabs with very heavy reinforcement

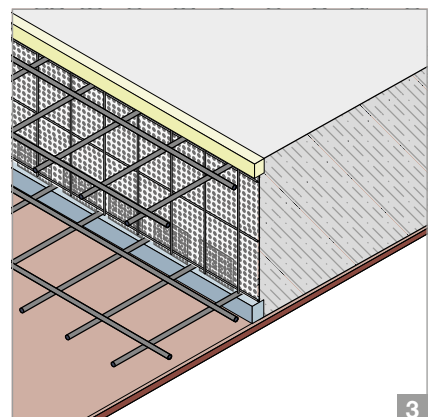
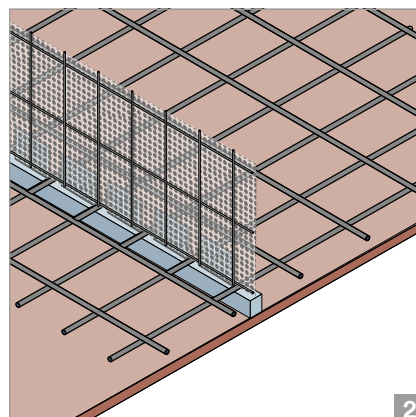
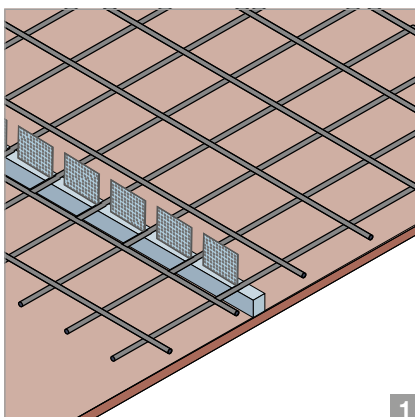
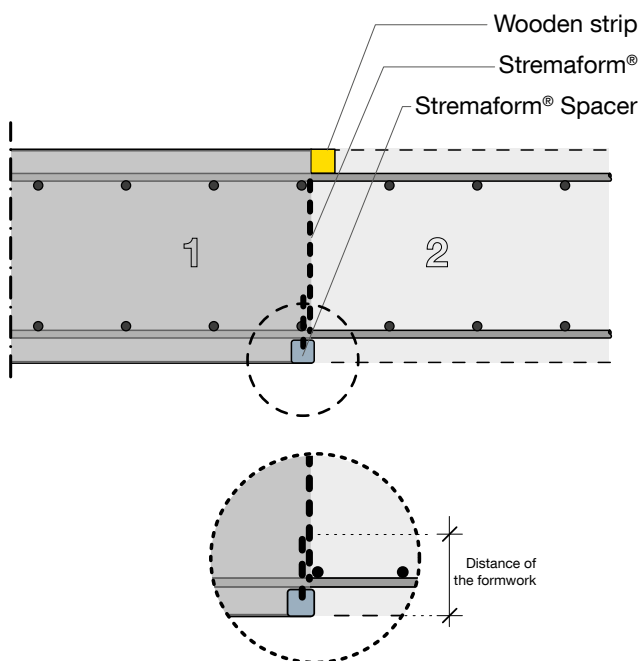
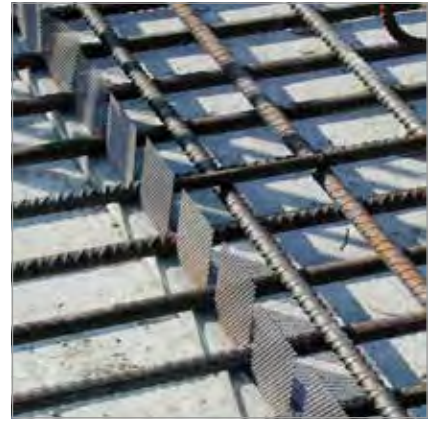

Stremaform® flat material

Stremaform® flat material is used as lost formwork for working joints in floor slabs, ceilings and walls. The expanded metal that is welded between the specially designed steel reinforcement mesh produces a rough surface that avoids the need for subsequent scabbling of the concrete surface prior to a second pour. This surface forms an indented structure with the second concrete pour so that shear forces are transmitted across the working joint just as though it were a monolithic construction (proven by tests carried out at the IBMB Brunswick).

- Optimal static bonding of the joint
- Maximizing off-site prefabrication minimizes work on the construction site and guarantees fast progress of the project
- No need for formwork removal or any other finishing work

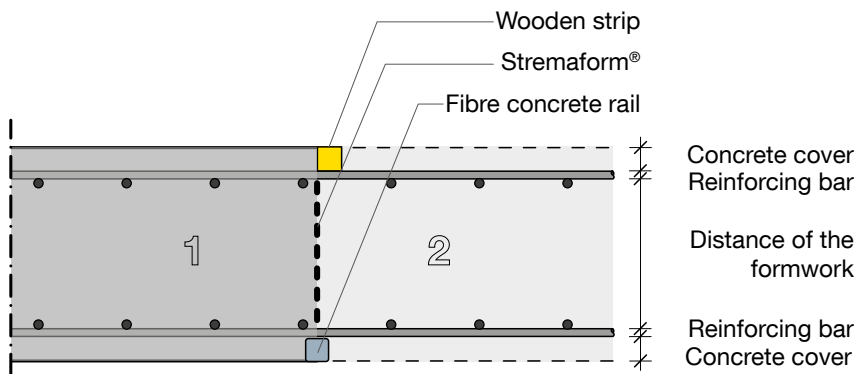
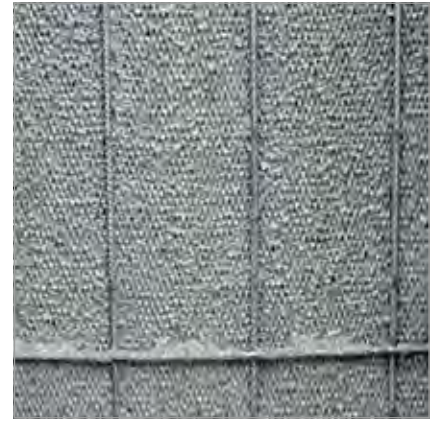

**Stremaform®
formwork element
slab/ceiling**

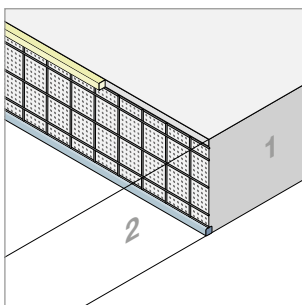

**Stremaform®
formwork element
wall**

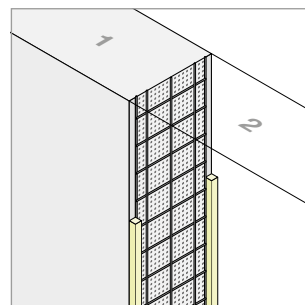

Stremaform® strong

Stremaform® strong formwork elements are of similar construction as Stremaform® flat material but with added reinforcement girders. The size and positioning of girders can be arranged to accommodate any wall thickness or slab depth. The use of back bracing means that these formwork elements are self-supporting when installed in accordance with our Guidelines.

- Ideal for large structural components
- Rear anchoring in the first concrete pour – hence no additional formwork elements are required for the second concrete pour
- Installed Stremaform® formwork elements remain in the concrete and reinforcement layout is unaffected

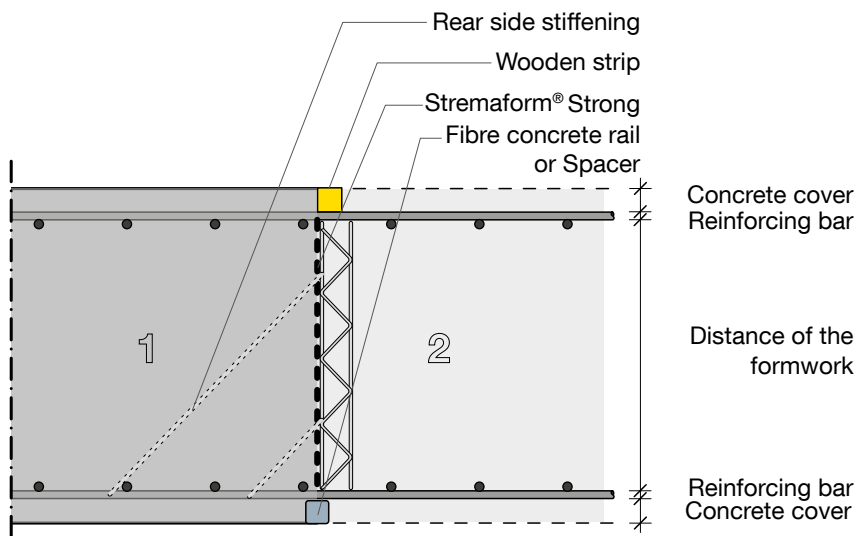

Stremaform® Strong formwork element slab/ceiling

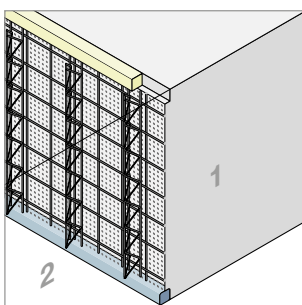

Stremaform® Strong formwork element wall

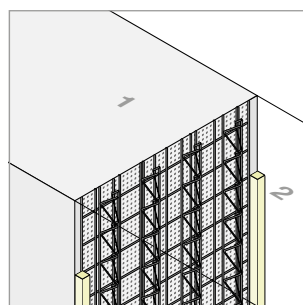

Stremaform® with indented joint

All Stremaform® formwork elements can be manufactured with one or more indented joints.

The standard indented joint meets the requirements of DIN EN 1992-1-1.

- Geometry of the indented joint can be tailored to your layout specifications
- Indented joint and factory stiffening (Stremaform® strong) can be combined
- All elements can be supplied with an integrated metal water stop or rubber waterbar cage

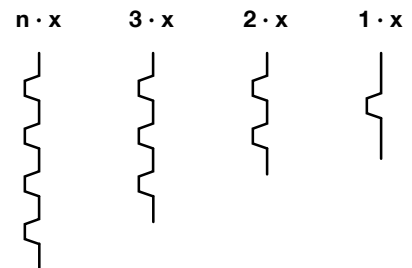
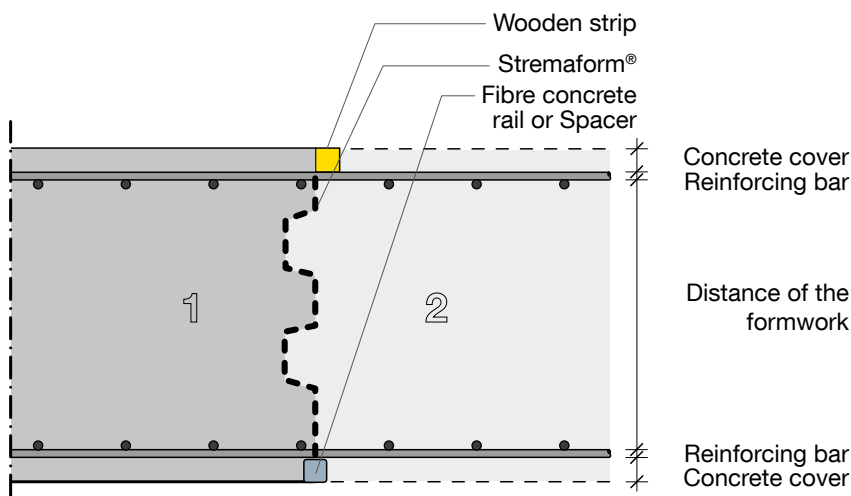

Stremaform® with indented joint floor slab/ceiling

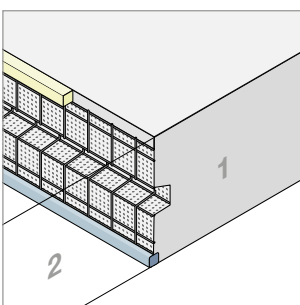

Stremaform® strong with indented joint floor slab/ceiling

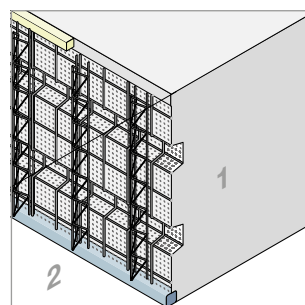

Stremaform® strong with indented joint wall

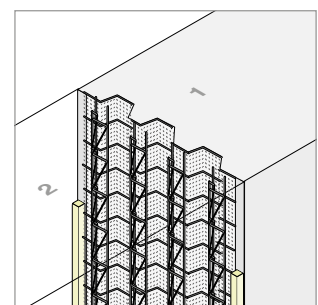

Stremaform® with metal water stop

All Stremaform® formwork elements can be supplied with a metal water stop. The jointing plate is available in standard widths of 250 mm or 300 mm or according to your specifications.

To prevent void formation under the metal water stop during concrete placement, the water stop can be angled upwards by 15° on both sides.

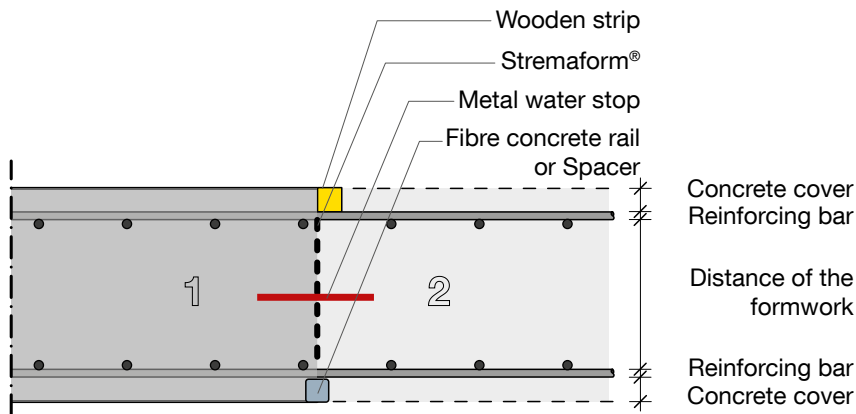

Stremaform® with metal water stop slab/ceiling

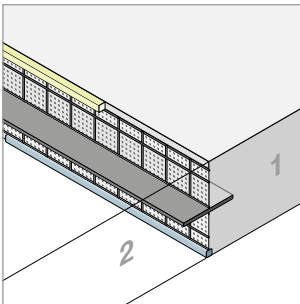

Stremaform® with metal water stop wall

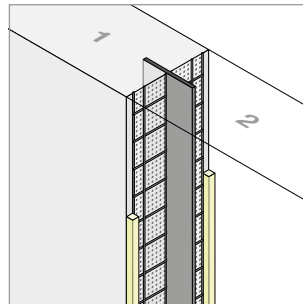

Stremaform® with coated metal water stop

The Stremaform® formwork elements already have a coated metal water stop integrated to function as a water bar.

metal water stop: 1.5 mm thick, 150 mm wide

One-sided coating 2 x 50 mm or double-sided coating can be supplied on request

Stremaform® with coated metal water stop slab/ceiling

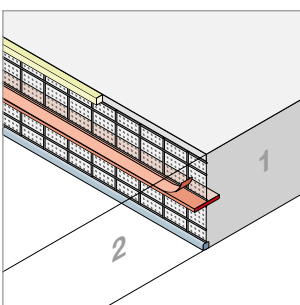

Stremaform® with coated metal water stop wall

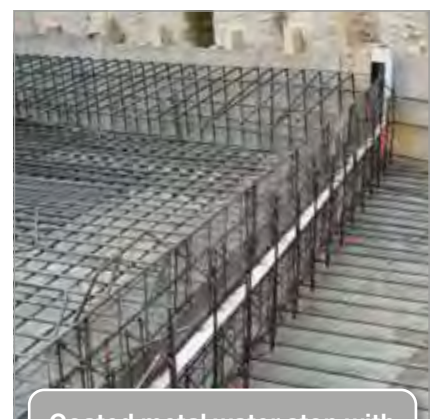
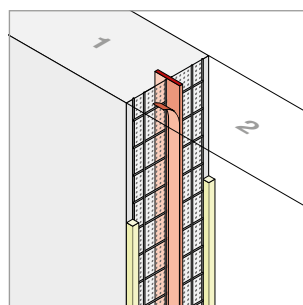

Coated metal water stop with European technical assessment (ETA)

Stremaform® with pvc/rubber water bar cage

All Stremaform® formwork elements can be supplied with a rubber water bar cage for on-site installation of a rubber water bar.

The rubber water bar cage is available in standard widths of 200 mm, 250 mm and 320 mm. Other dimensions are possible.

To prevent void formation, a rubber water bar cage with both sides angled upwards by 15° can be supplied.

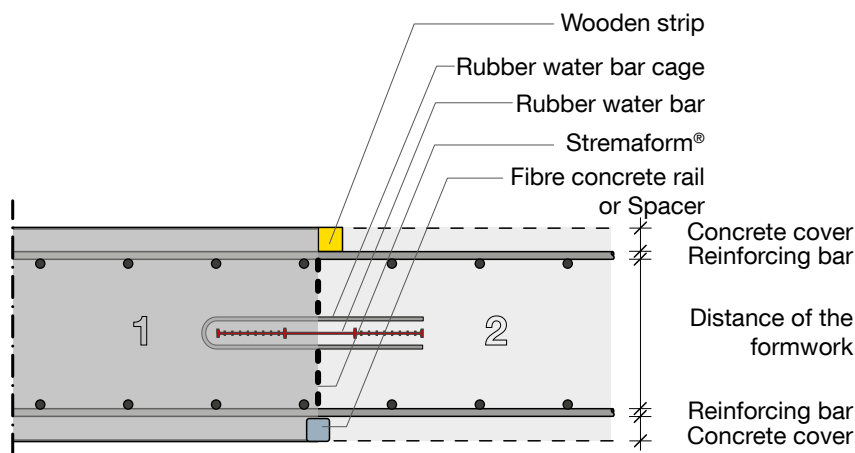

Stremaform® formwork element with pvc/rubber water bar cage slab/ceiling

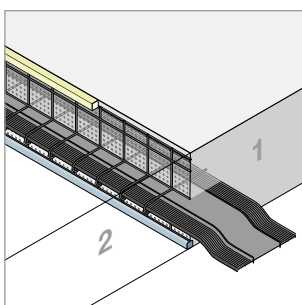

Stremaform® formwork element with pvc/rubber water bar cage wall

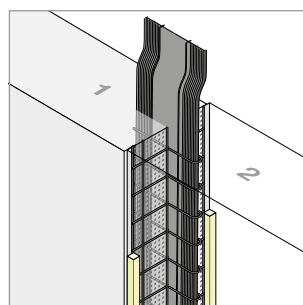

Stremaform® fixing anchor

Stremaform® fixing anchors are used to maintain the positioning of Stremaform® formwork elements in working joints when on-site welding is not feasible or prohibited. Their use ensures tensile and pressure resistant anchoring of the formwork during the installation and concreting phases.

The fixing anchor consists of a loop hook with safety bolt for hanging into the lower reinforcement, a tension rebar and a spring clamp. Stremaform fixing anchors are recommended for slab widths > 1.0 metre.

- Quick assembly due to high degree of prefabrication
- No welding is required on site for fixing the Stremaform® formwork element in place
- The spring clamp is reusable

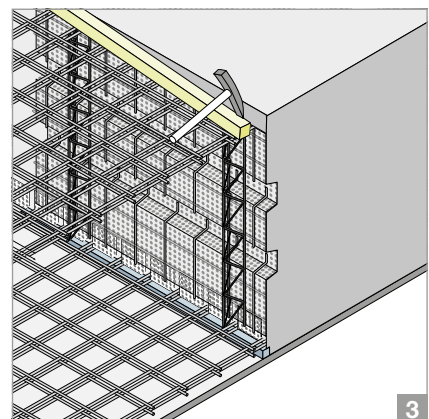
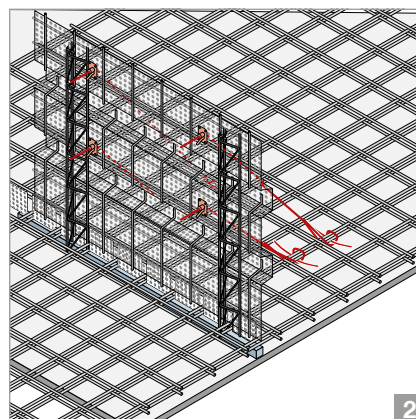
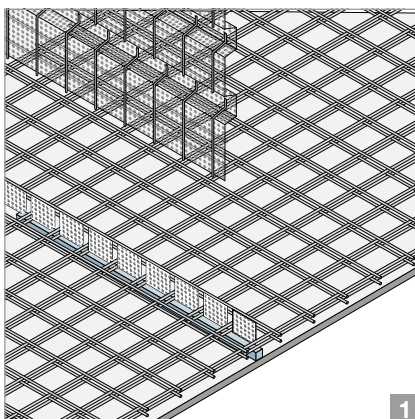
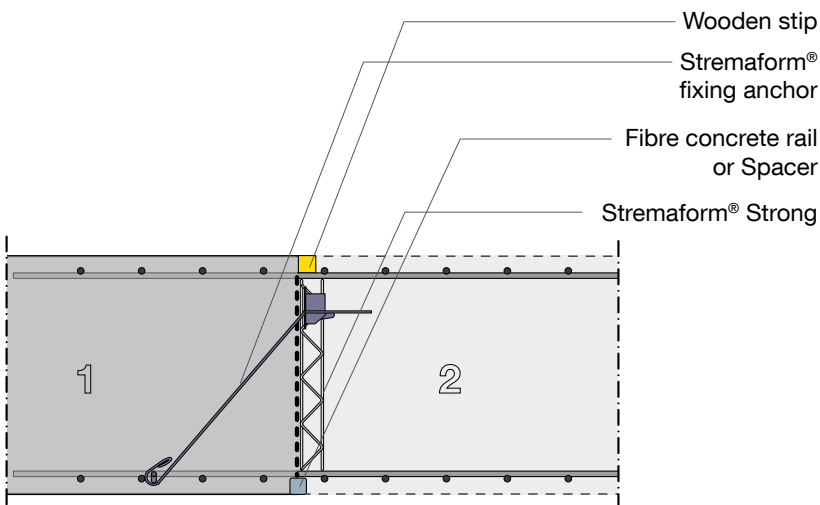

Stremaform® formwork for underwater elements

Stremaform® formwork elements for underwater base slabs are factory-made formwork elements that are delivered to site unassembled. On dry land at the site, the vertical and horizontal components are erected and supported by the diagonal bracing. Components can be screwed/welded together.

The assembled units are then lowered into the water and positioned with the units remaining dimensionally stable under water.

Concrete should commence from the rear towards the face and evenly over the horizontal part and raised evenly to prevent undue pressure on the vertical section of the element. The weight of concrete stabilises and secures the Stremaform® formwork element during concreting.

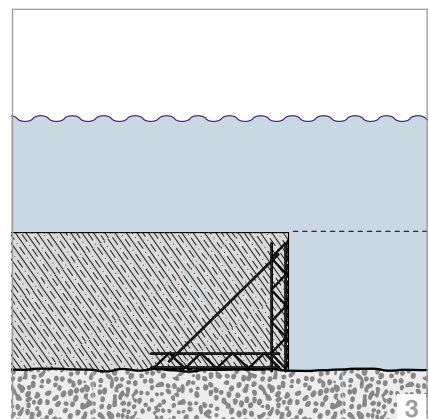
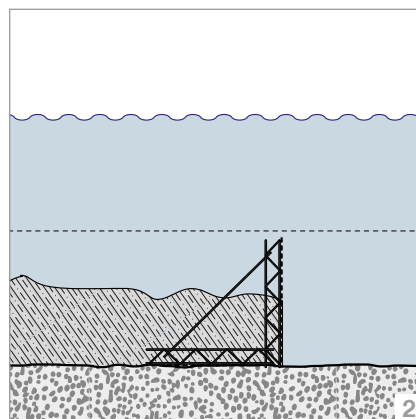
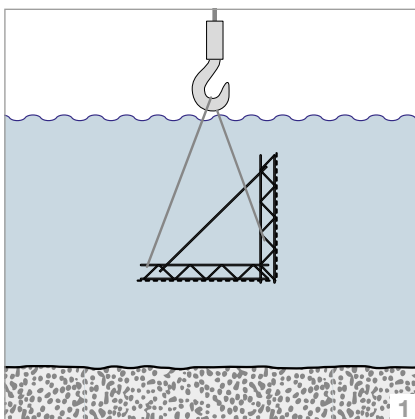
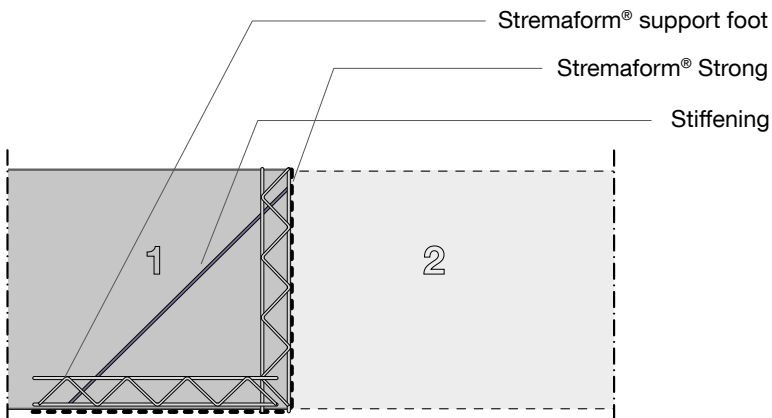

Stremaform® kicker formwork

Kicker formwork between floor slab and wall, or between wall and ceiling, can optionally be manufactured with a metal water stop (with or without coating) or with a rubber water bar cage ready for on-site installation of a working rubber water bar.

Moulded elements such as cross pieces, T-pieces and angled elements as well as pre-curved elements are available and facilitate installation at the construction site.

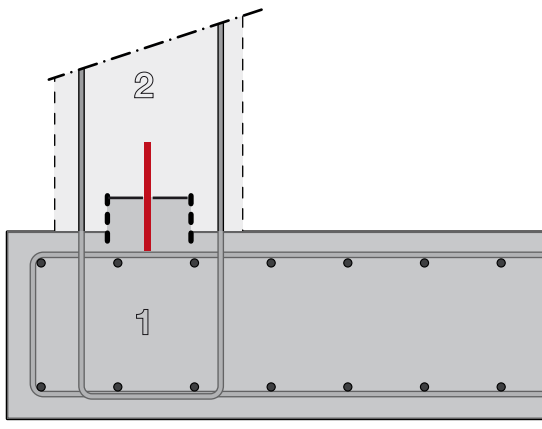
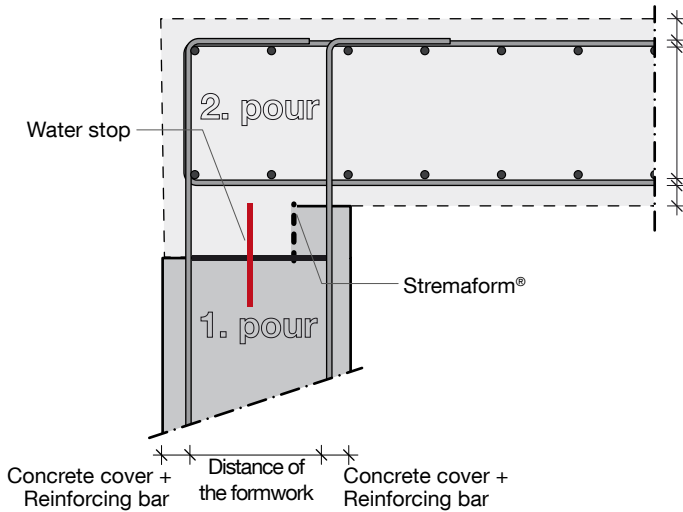

**Stremaform®
kicker formwork
with metal water stop**

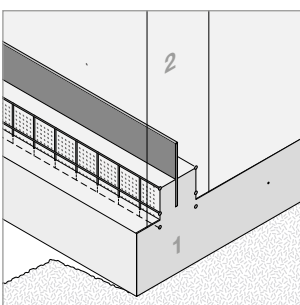

**Stremaform®
kicker formwork with
coated metal water stop**

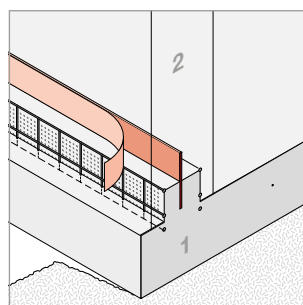

**Stremaform®
formwork element with
pvc/rubber water bar cage**

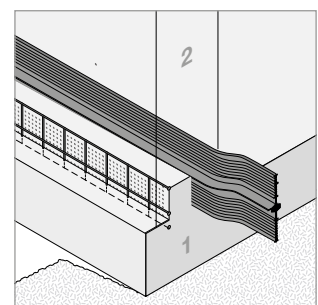

Stremaform® “A-Bock” – free standing formwork elements

The free-standing formwork elements are positioned on top of the lower reinforcement layer. The construction also serves as a support frame between the lower and upper reinforcement. Monolithic bonding of the slab is guaranteed.

The free-standing elements for floor slabs and ceilings are available in various heights from an installation dimension of 80 mm.

- Economically priced formwork elements with quick installation, offer all benefits of Stremaform®
- Easy installation of upper reinforcement by simple positioning

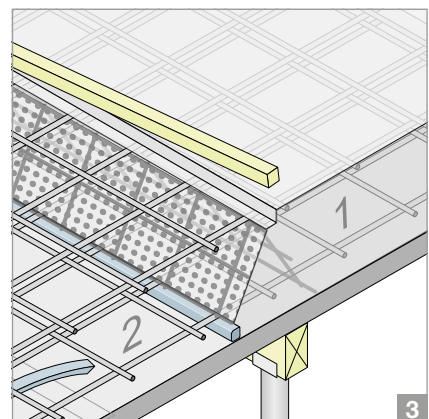
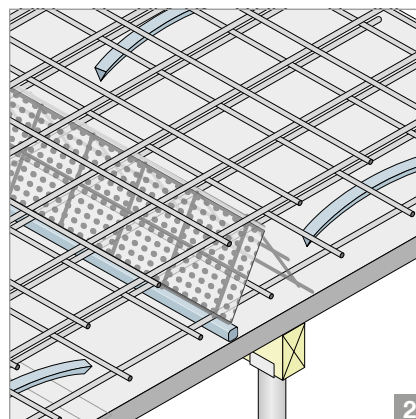
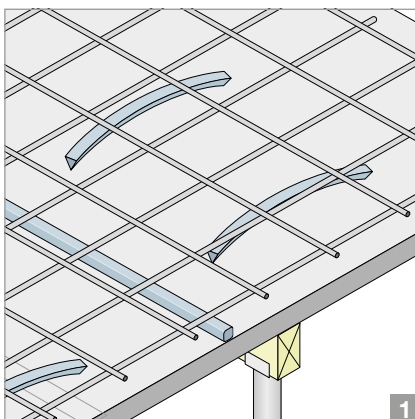
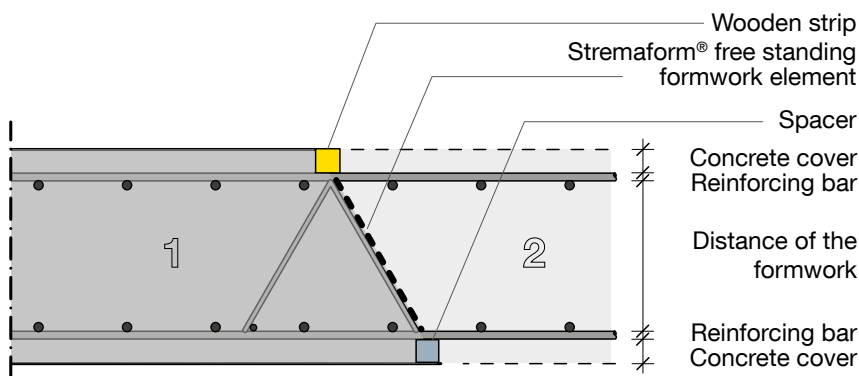

Stremaform® foundation box-outs

Stremaform® formwork elements are used to form box-outs in foundations that are used as a recess for subsequent production of supports and columns. After completion of the foundation slab or individual foundations, steel or reinforced concrete columns can be positioned exactly according to the layout.

The internal surface of the box-out produced by Stremaform® formwork elements is perfectly indented. Between the column and base slab there is a positive connection after pouring of the infill concrete.

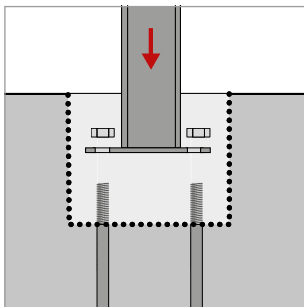

**Stremaform®
foundation box-outs**

Using a Pecafil® external formwork in combination with Stremaform® internal formwork, individual column foundations can be easily and economically produced.

Pecafil® formwork elements can be reused for several identical foundations. They can be easily moved to a new position manually without the need for lifting equipment.

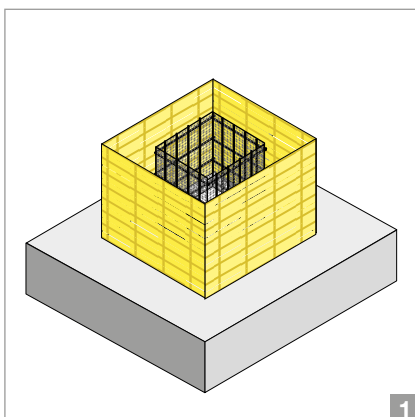

1

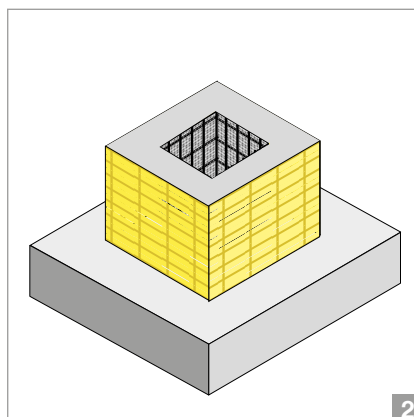

2

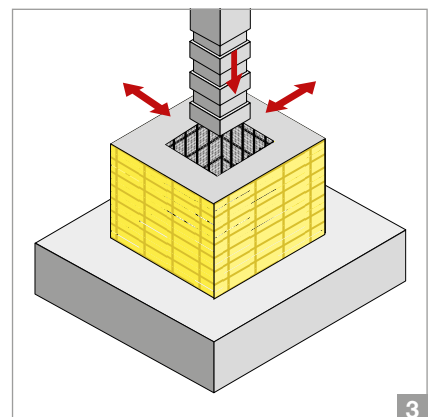

3

Stremaform® box-outs

Stremaform® formwork elements for box-outs are used for wall or slab openings. These openings for e.g. large diameter pipe leadthroughs, are subsequently filled with concrete. Stremaform® formwork elements for recesses are available in various designs and sizes. Many options are available, such as elements with stiffening, concrete cover rails, chutes, with seals and wooden covers used as drop or fall arrest protection.

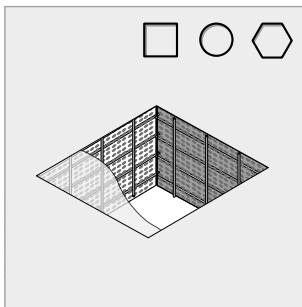

Stremaform®
formwork element

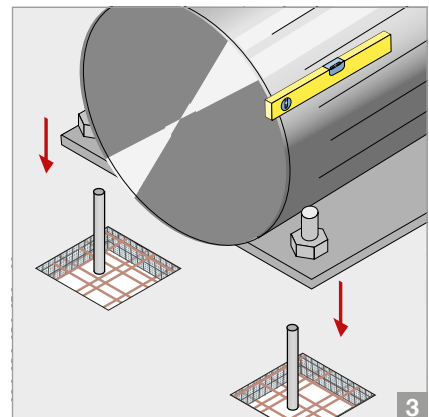
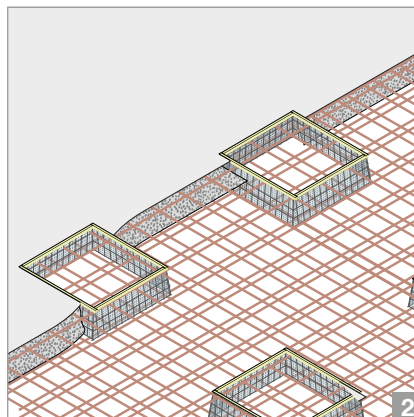
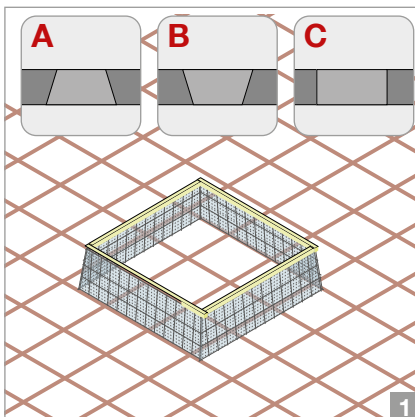

Stremaform® hopper formwork

Hopper formwork elements are used to produce conical concrete structures (e.g. for wastewater treatment plants or silos) where they form the upper formwork. The surface is subsequently covered with a screed to the required concrete cover. Fixing at the bottom via anchors / lift protectors prevents the risk of flotation.

Stremaform® hopper formwork elements can also be supplied complete with factory-made bracing.

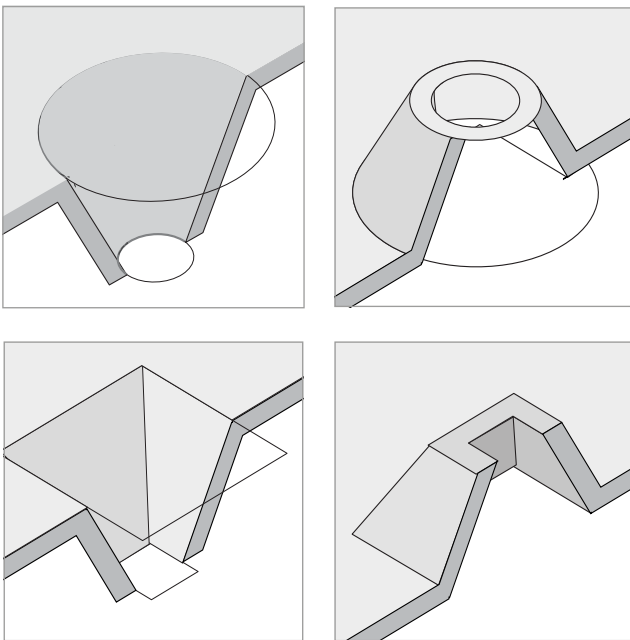
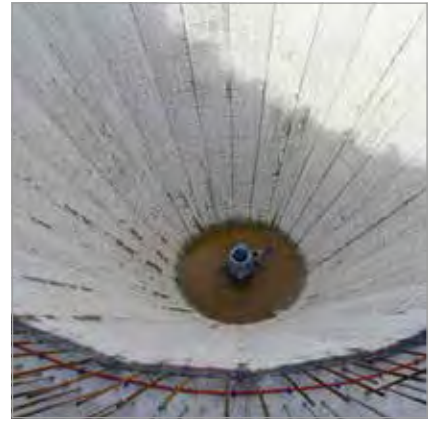

Stremaform®
hopper formwork

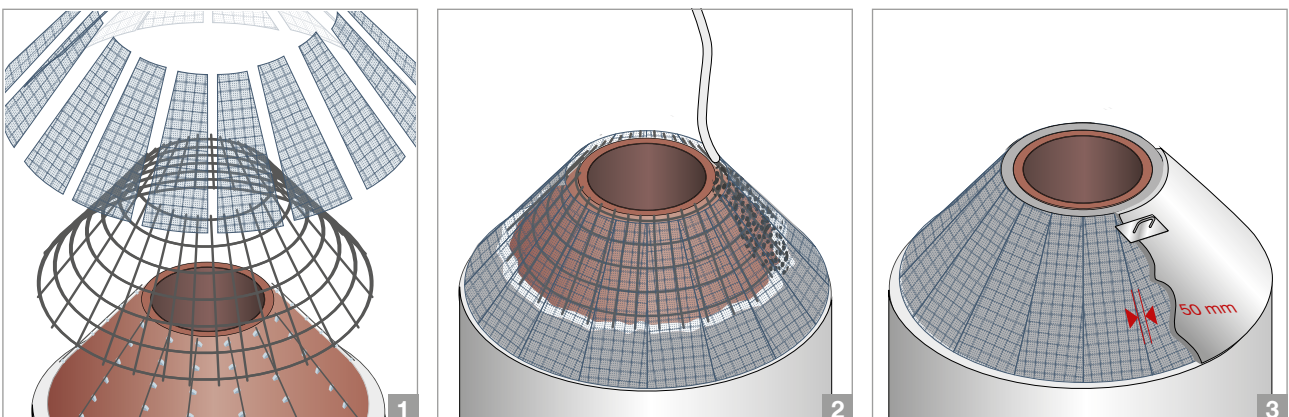

Stremaform® for controlled crack joints

Stremaform® formwork elements for controlled crack joints prevent a connection between concreted sections over at least 1/3 of the structural element thickness, in order to produce a controlled crack.

Depending upon their individual design, Stremaform® elements for controlled crack joints can be used to produce intended cracks

- for formwork
- for monolithic concrete structures

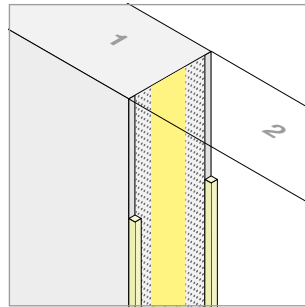
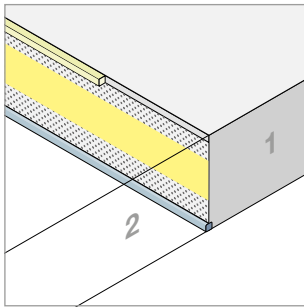
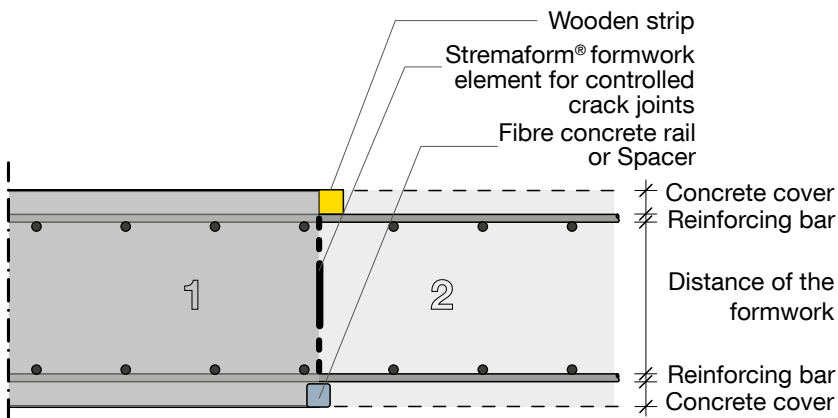

Stremaform® controlled crack joint element for formwork

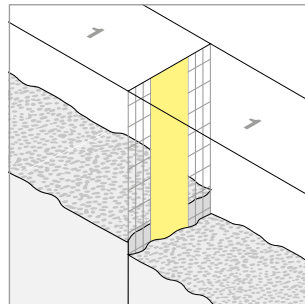
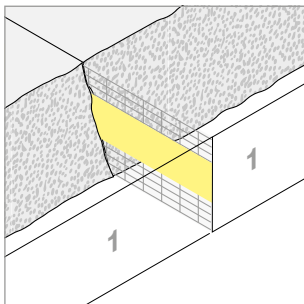

Stremaform® controlled crack joint element for continuous concreting

Stremaform® for controlled crack joints with coated metal water stop

Stremaform® formwork elements for controlled crack joints prevent a connection between concreted sections over at least 1/3 of the structural element thickness, in order to produce a controlled crack.

Weakening of the cross section is achieved by integrating a separation layer with a width of one third of the component cross section.

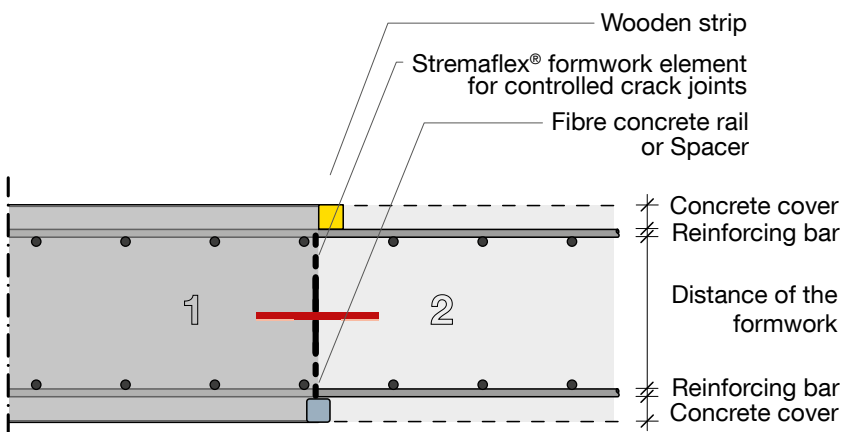

Stremaform® for controlled crack joints with pvc/rubber water bar cage

The rubber water bar cage is intended for on-site installation of a working rubber water bar. It is available in widths of 200 mm, 250 mm and 320 mm or can be manufactured to your specifications.

An integrated separation layer with a width of one third of the component cross section provides weakening of the cross section.

A water bar cage that is angled upwards by 15° on both sides can be chosen for void-free concreting.

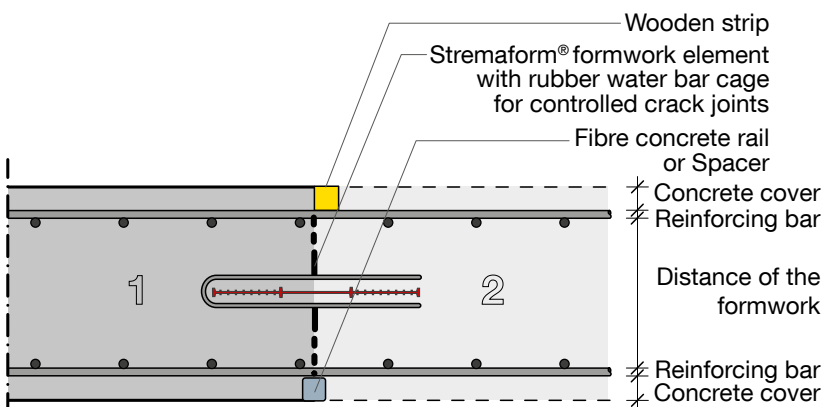

Stremaform® for expansion joints

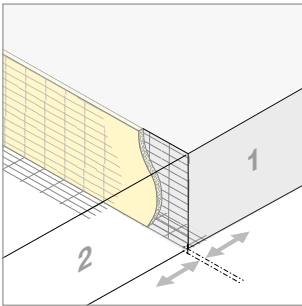

Stremaform® expansion joint with polystyrene

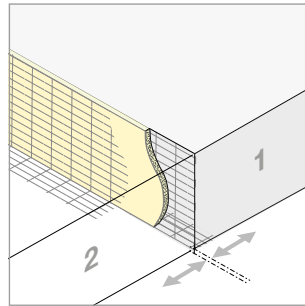

Stremaform® expansion joint with mineral wool (fire protection)

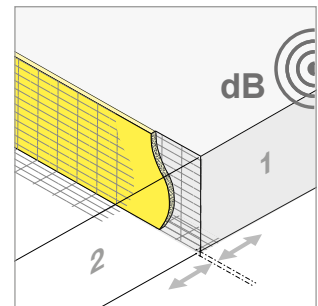

Stremaform® sound joint

Stremaform® for expansion joints with water stop

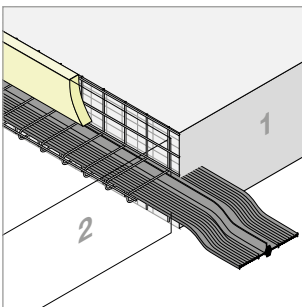

Stremaform® expansion joint with one-sided rubber water bar cage

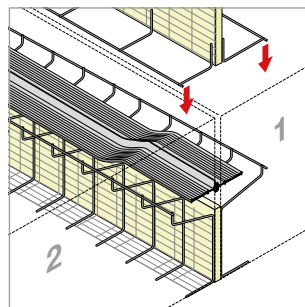

Stremaform® expansion joint with two part rubber water bar cage

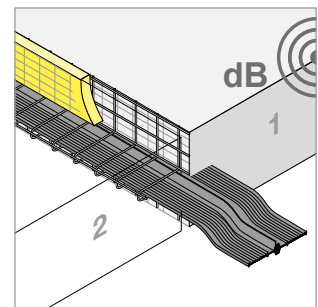

Stremaform® sound joint with rubber water bar cage

Stremaform® for expansion joints with transverse force transmission

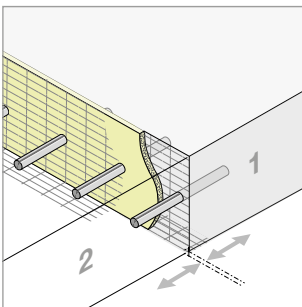

Stremaform® expansion joint with transverse force dowels (Egcodubel)

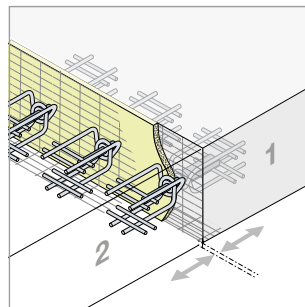

Stremaform® expansion joint with transverse force dowels (Egcodorn WN/WQ)

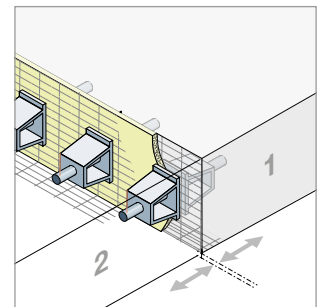

Stremaform® expansion joint with transverse force dowel for dynamic loads (Egcodorn DND)

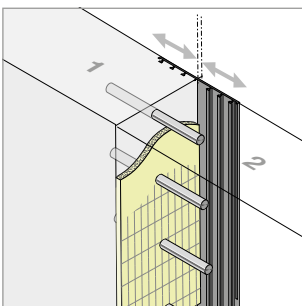

Stremaform® expansion joint with transverse force dowel (Egcodubel) and rubber water bar

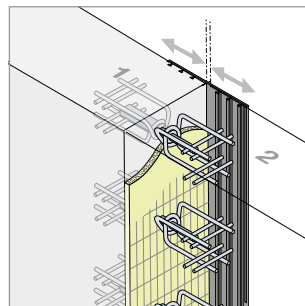

Stremaform® expansion joint with transverse force dowel (Egcodorn WN/WQ) and rubber water bar

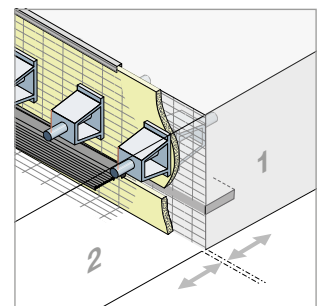

Stremaform® expansion joint with transverse force dowel for dynamic loads (Egcodorn DND) and rubber water bar

Stremaform® for expansion joints

Stremaform® formwork elements can also be used for separation of structural elements for expansion joints. These elements consist of a filler material sandwiched between a metal support structure. The filler material used for the expansion joint can be polystyrene or heat resistant mineral wool. Stremaform® formwork elements remain as part of the finished structure and there is no need for formwork stripping.

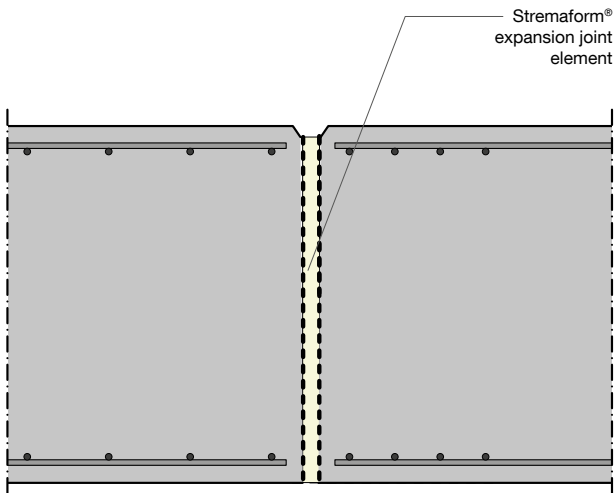
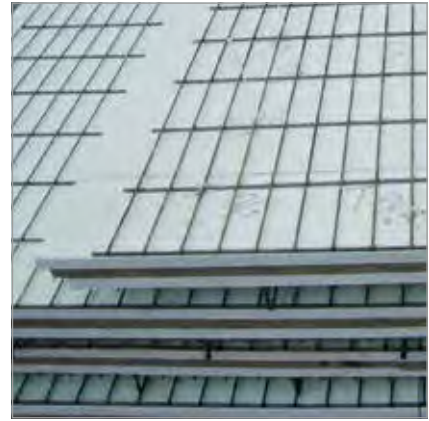

Select the expansion joint insert according to your needs:

Styrodur	Mineral fibre	Galvanised / stainless steel
Standard design	for high fire protection requirements (heat resistant to 1000 °C)	for high requirements with regard to corrosion protection

All expansion joints listed on the following pages are available in these designs.

Stremaform® with rubber water bar cage for expansion joints

Stremaform® formwork elements can be fitted with a rubber water bar cage for subsequent installation of a rubber water bar at the construction site. The integrated Stremaform® fixing devices ensure that the central bulb of the rubber water bar is maintained centrally in the joint before and after the concrete pour.

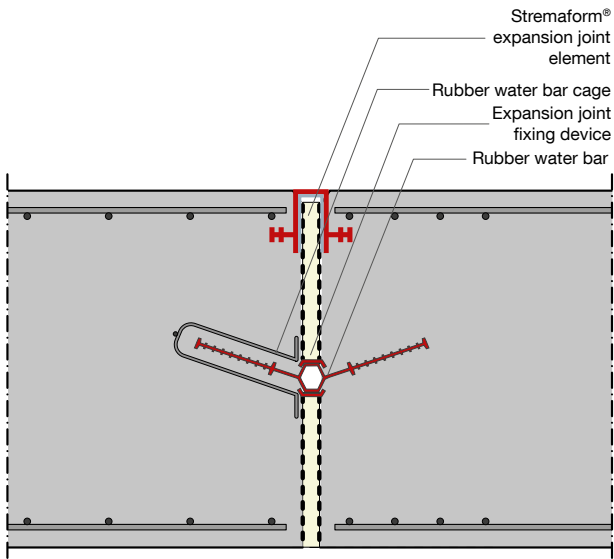

Stremaform® with two part rubber water bar cage for expansion joints

For ease of installation of the rubber water bar, we recommend the use of formwork elements with 2 part rubber water bar cages. After installing the lower part, the rubber water bar is simply unrolled and then the upper part is installed.

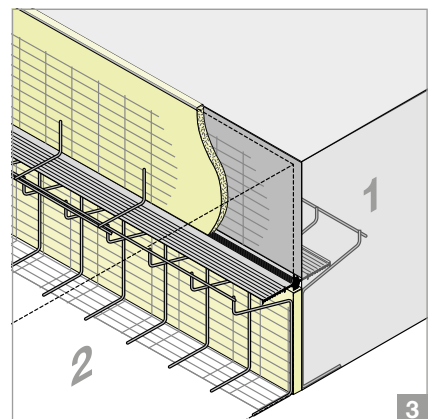
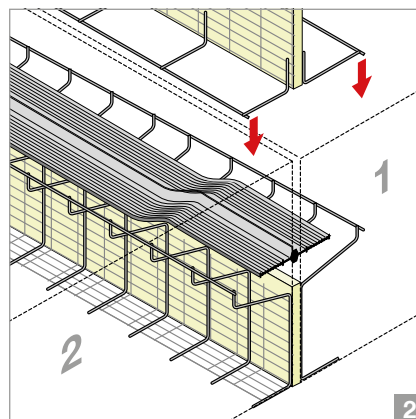
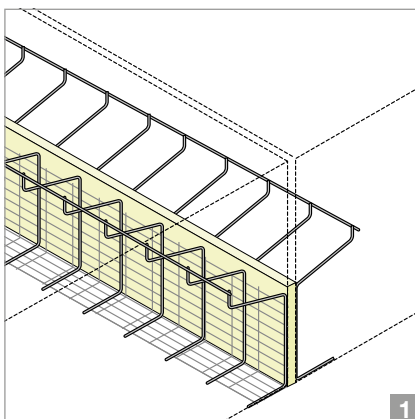

Stremaform® with integrated transverse force dowels for expansion joints

All Stremaform® formwork elements for expansion joints can be supplied with integrated transverse force dowels (Egcodubel or Egcodorn). Transverse force dowels (Egcodorn and Egcodubel) permit movement in both directions in the plane of the slab.

The use of transverse force dowels (Egcodubel) is restricted to ancillary components such as industrial floors or structural connections. The transmittable loads are lower than for transverse force dowels (Egcodorn).

Thanks to their anchor bodies, transverse force dowels (Egcodorn) are able to transmit very high loads, even with minimal component thicknesses. The transverse force dowels (Egcodorn) are integrated into the working joint elements at the factory, thus minimising the assembly time and demands on the workforce at the construction site.

Rubber water bar cages for sealing the joints can be integrated into the formwork elements.



Stremaform® formwork elements for expansion joints with transverse force dowels (Egcodubel)

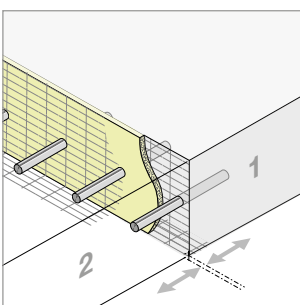

Stremaform® formwork elements for expansion joints with transverse force dowels (Egcodorn WN/WQ)

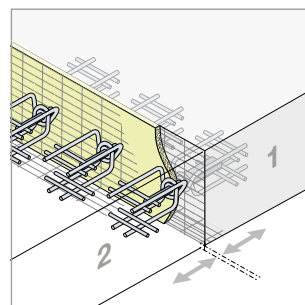

Stremaform® with integrated dynamic transverse force dowels for expansion joints

Mass-spring systems are used to prevent the transfer of vibrations and for railways this means resting concrete bases on a resilient material. This creates strains and at expansion joints it is necessary to transfer dynamic forces across the joint. These dynamic forces can be transferred via the use of special dynamic transverse force dowels (Egcodorn type DND). To speed up work cycles at the construction site we manufacture and deliver prefabricated units consisting of the Egcodorn dowels integrated into Stremaform® formwork element for expansion joints. These units are simply dropped into position and tied into the main reinforcement. This type of construction ensures fast and accurate placement of the dowels and expansion joint material and ensures uninterrupted work progress, thus speeding up completion of concrete structures, i.e. a major benefit especially for tunnel construction.

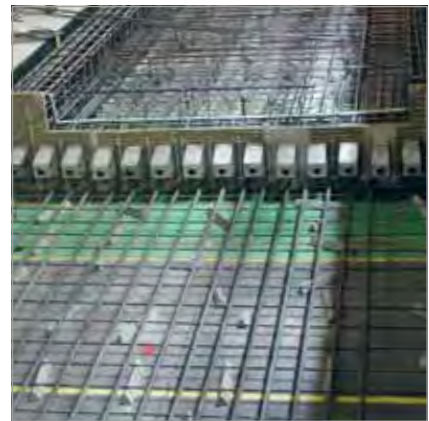

Stremaform® formwork elements for expansion joints with transverse force dowels (Egcodorn DND)

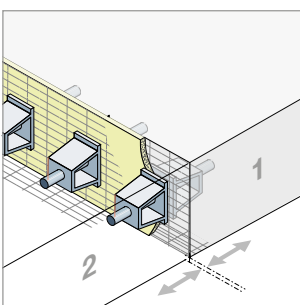

Stremaform® formwork elements for expansion joints with transverse force dowels (Egcodorn DND) and pvc/rubber water bar

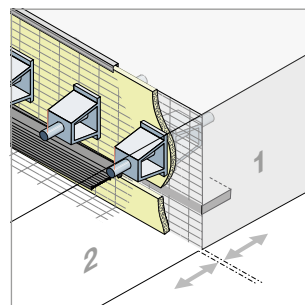

Order form - Stremaform® working joints

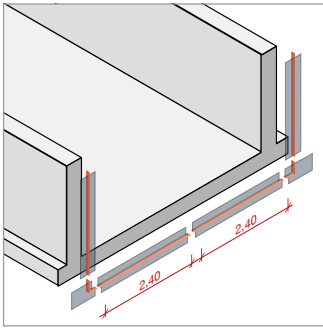

Formwork for concrete pours

Stremaform® formwork is the leading, ready-to-install solution for working joints as it is a stay-in-place formwork for concrete slabs or walls. MAX FRANK has more than 30 year's experience in developing, producing and supplying Stremaform® to iconic projects worldwide.

This order sheet has been designed to document your project requirements quickly and efficiently. Please send the form to the below address and we will provide a quotation for your requirements:

Max Frank GmbH & Co. KG
 Mitterweg 1
 94339 Leiblfling
 Tel. +49 9427 189-0
 info@maxfrank.com

Project name:
 Site address:
 Site contact:

Type of construction

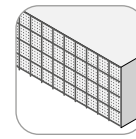

slab

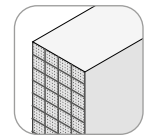

wall

Waterproofing

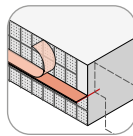
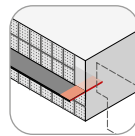
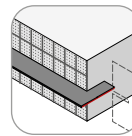
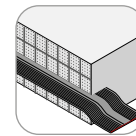
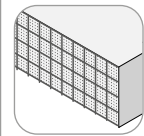

 coated metal water stop
 (Page 33)

 water stop with coating at the splice
 (Page 34)

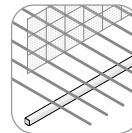
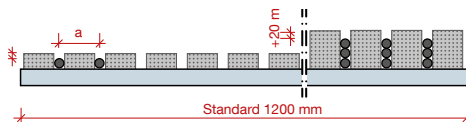
 metal water stop with overhang/slot
 (Page 35)

 carrying cage for rubber/
 PVC water stop
 (Page 36)

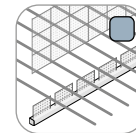
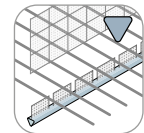
 without waterproofing
 (Page 37)

Stremaform® spacer for efficient mounting

overall length L: mm
 spacing a: mm
 cover c_{nom} : mm



without Stremaform® spacer

 with Stremaform® spacer
 (square bar)

 with Stremaform® spacer
 (triangular)

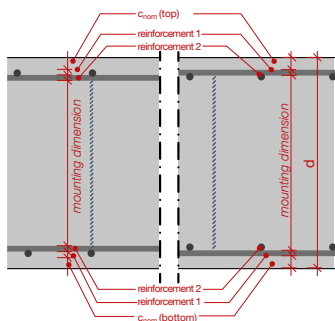
Layout



slab depth d mm

top: top cover $c_{nom\ top}$ mm

T 1 \varnothing mm , number of layers n pc.
 T 2 \varnothing mm , number of layers n pc.

mounting dimension EBM mm

bottom: B 1 \varnothing mm , number of layers n pc.
 B 2 \varnothing mm , number of layers n pc.

bottom cover $c_{nom\ bottom}$ mm

Mounting dimension - recommendation

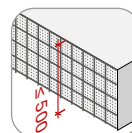
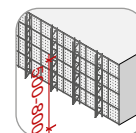
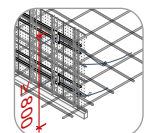
 flat material
 $h < 500\ mm$

 Stremaform® strong
 $500\ mm < h < 800\ mm$

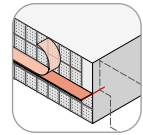
 Stremaform® strong +
 Stremaform® bracing
 $h \geq 800\ mm$

Order form - Stremaform® working joints coated metal water stop

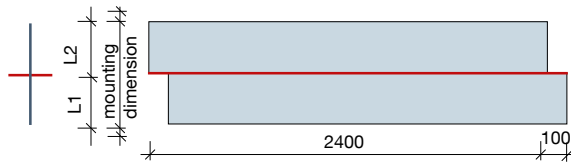

Position of the water stop



mounting dimension EBM: mm
 water stop in center: yes no
 top distance (L2) mm
 bottom distance (L1) mm

Please mark up any height offsets!

Wall transition unit

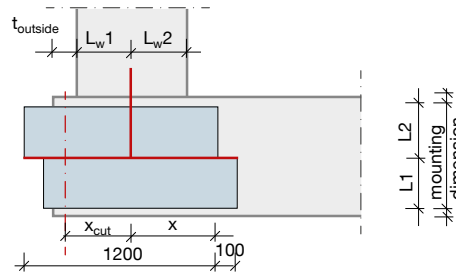

Wall dimensions
 t_{outside} mm
 L_{w1} mm
 L_{w2} mm
Slab dimensions
 x_{cut} mm
 x mm
 (mounting dimension see above)

Metal water stop

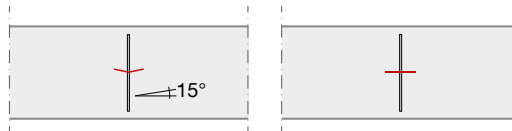

angled straight

type of metal water stops
 Standard 150/1.5 mm

metal water stop dimension
 width/thickness=/..... mm

Coating: one-sided double-sided

Units

forms of supply (standard)

① Standard 2400 mm

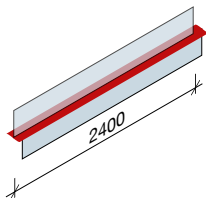

② Standard 1200 mm

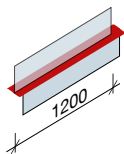

③ Wall transition unit

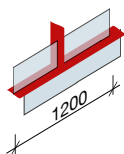

④ Height offset

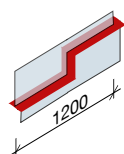

⑤ Corner element

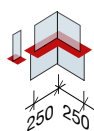

⑥ T-element

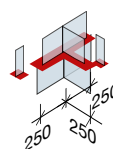

⑦ Crossing

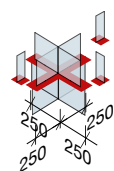

Order form - Stremaform® working joints metal water stop with coating at the splice

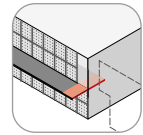

Position of the water stop

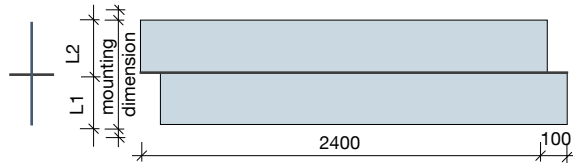

mounting dimension EBMmm

 water stop in center yes no

top distance (L2) mm

bottom distance (L1) mm

Please mark up any height offsets!

Wall transition unit

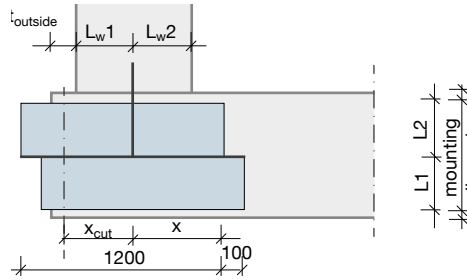

wall dimensions

 t_{outside} mm

 L_{w1} mm

 L_{w2} mm

slab dimensions

 X_{cut} mm

X mm

(Mounting dimension see above)

Metal water stop

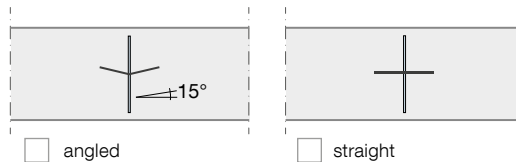
 angled

 straight

type of metal water stops

 250/1.5 mm

 250/2.0 mm

 300/1.5 mm

 300/2.0 mm

/.....mm

Units

forms of supply (standard)

① Standard 2400 mm

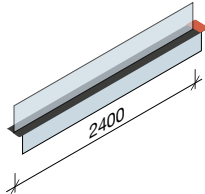

② Standard 1200 mm

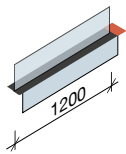

③ Wall transition unit

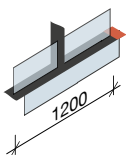

④ Height offset

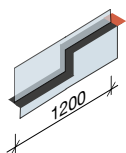

⑤ Corner element

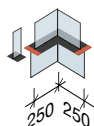

⑥ T-element

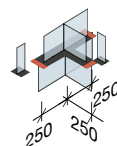

⑦ Crossing

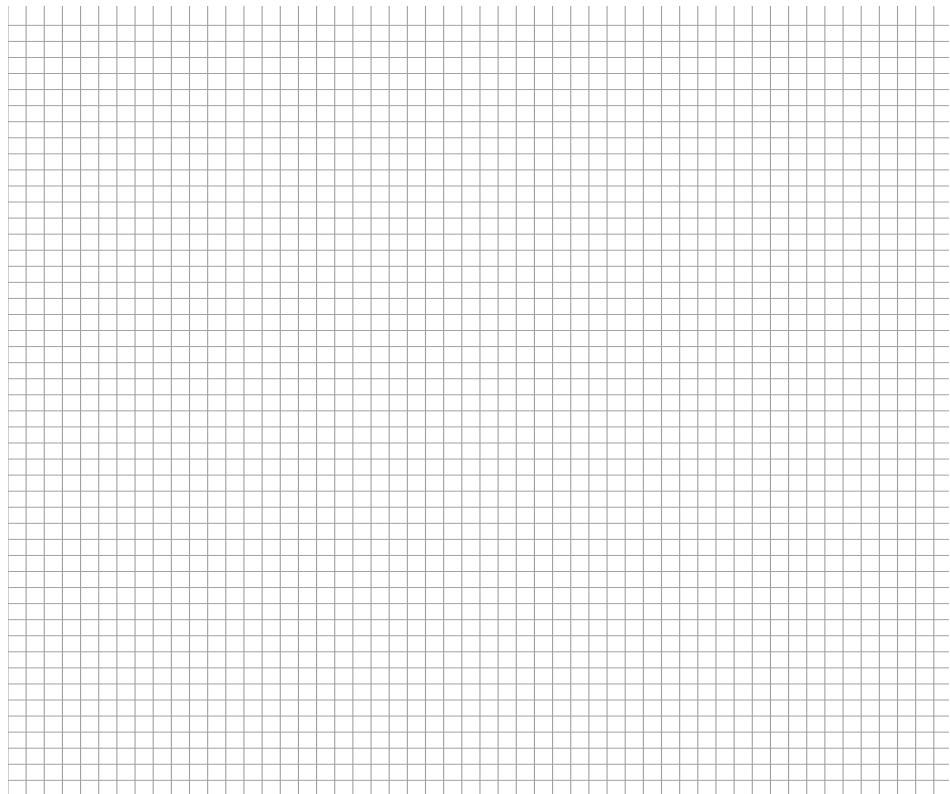
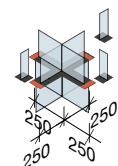

Order form - Stremaform® working joints metal water stop

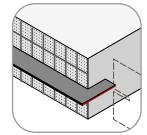

Position of the water stop

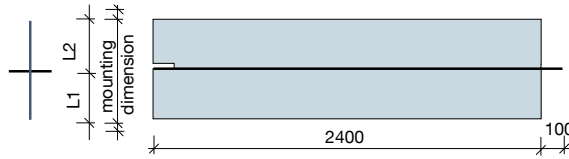

mounting dimension EBM mm
 water stop in center yes no
 top distance (L2) mm
 bottom distance (L1) mm

Please mark up any height offsets!

Wall transition unit

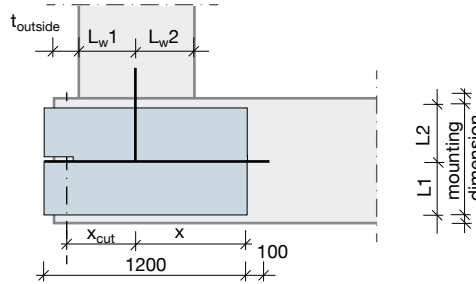

wall dimensions
 t_{outside} mm
 L_{w1} mm
 L_{w2} mm

slab dimensions
 x_{cut} mm
 x mm

(Mounting dimension see above)

Metal water stop

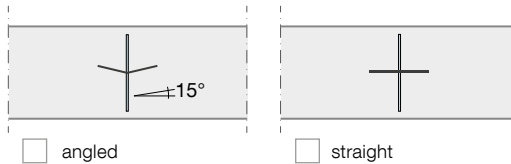

type of metal water stops

- 250/1.5 mm
- 250/2.0 mm
- 300/1.5 mm
- 300/2.0 mm
-/.....mm

Units

forms of supply (standard)

① Standard 2400 mm

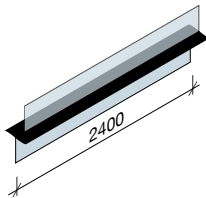

② Standard 1200 mm

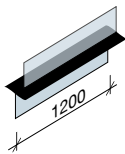

③ Wall transition unit

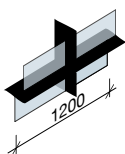

④ Height offset

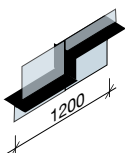

⑤ Corner element

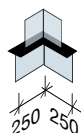

⑥ T-element

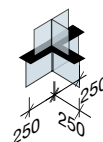

⑦ Crossing

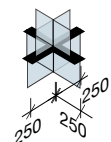

Order form - Stremaform® working joints without waterproofing

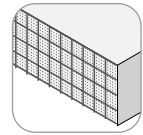

Dimension

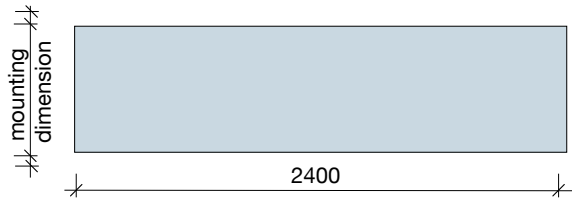

mounting dimension EBM: mm

Units

forms of supply (standard)

- ① Standard 2400 mm

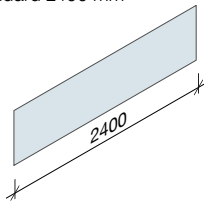

- ② Standard 1200 mm

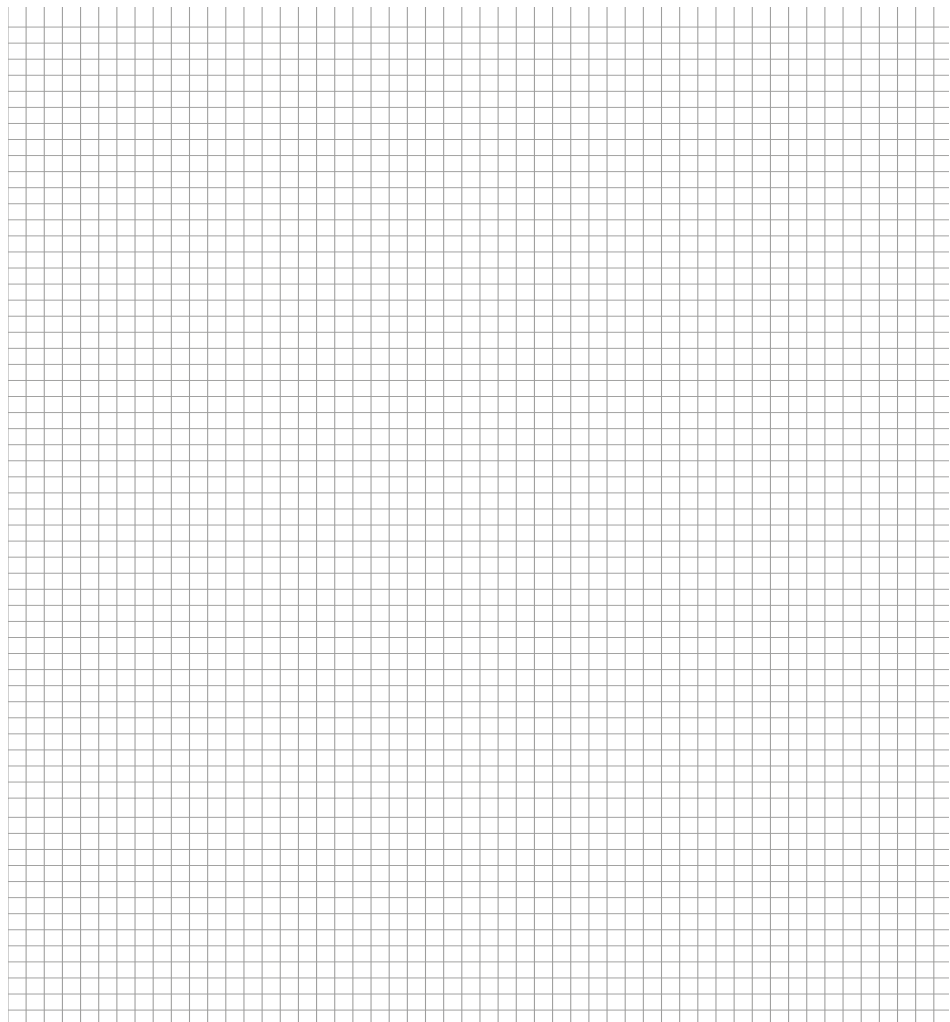
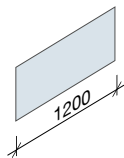

How tos

Crane foundation in concrete floor slab

In larger building projects, crane foundations are integrated directly into the floor slab and are the first areas to be concreted. This stage is extremely important for the construction, because the crane plays an instrumental role on the building site. Stremaform® concrete jointing formwork enables the working joints in the crane foundation to be created quickly, securely and with a force-locked connection. As standard, the Stremaform® working joint can also be prefabricated with integrated waterproofing materials and sealed against groundwater.

How to:

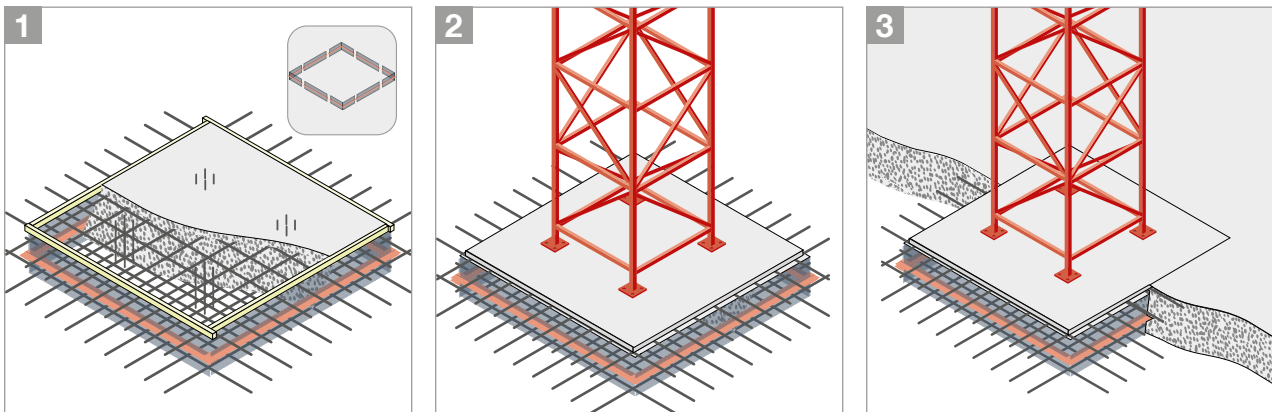

Simple manufacture of expansion joints with complex component cross sections

In cases of force transmission, sealing or special component geometries – there is a great deal of variation in the execution of expansion joints. For that reason, the manufacture of this formwork on the building site is often complex, unreliable and time-consuming.

Stremaform® formwork elements for expansion joints are prefabricated according to the project requirements and delivered as a precise fit.

How to:

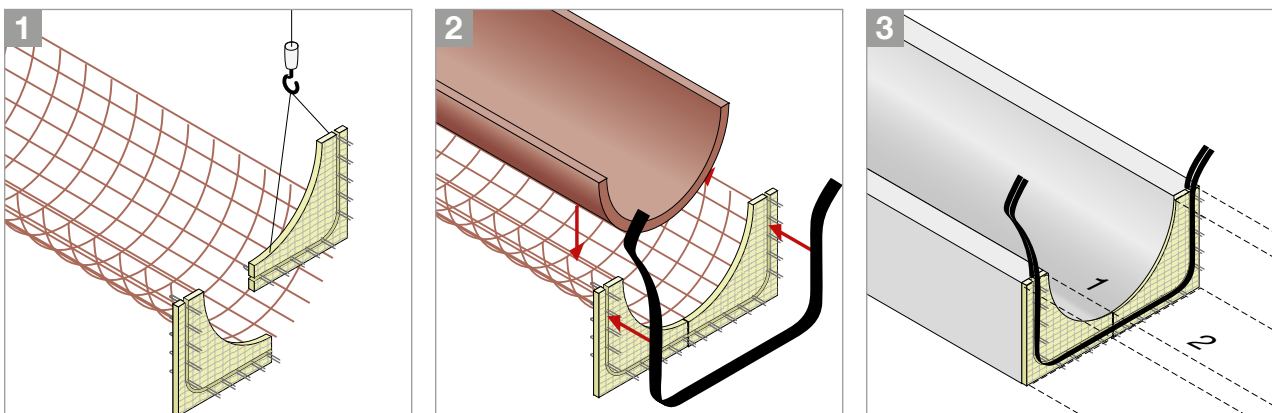

VISIT OUR NEW WEBSITE

www.maxfrank.com

By using our new responsive webdesign, you will be led through the new MAX FRANK website and will conveniently be receiving all requested contents, despite which Smartphone you choose.

Our website offers both information regarding our products and a wide range of exceptional services. Therefore you will find interesting features that support you through every building phase.



MAX FRANK BUILDINGS

This welcomed tool has been integrated into the website and is now even better connected to the detailed product information. The virtual landscape has been expanded for several new building types and now offers a perfect product range to include hydropower plants, industrial warehouses and railway stations.

PRODUCT FINDER

Filter easily by the requested scope of applications and product properties and you will be led directly through to the appropriate products allowing any challenges you have, to be solved.



Max Frank GmbH & Co. KG

Mitterweg 1
94339 Leiblfling
Germany

Tel. +49 9427 189-0
Fax +49 9427 1588

info@maxfrank.com
www.maxfrank.com